

DVRI-HCS • DISPLACEMENT DIFFUSER

HEATING & COOLING • AUTO-CHANGEOVER • SOLAR POWERED

DVRI-HCS 24" X 10" RECT. INLET

Model	Inlet Size	Nominal Unit Size
DVRI-HCS	10 x 24	36 x 81

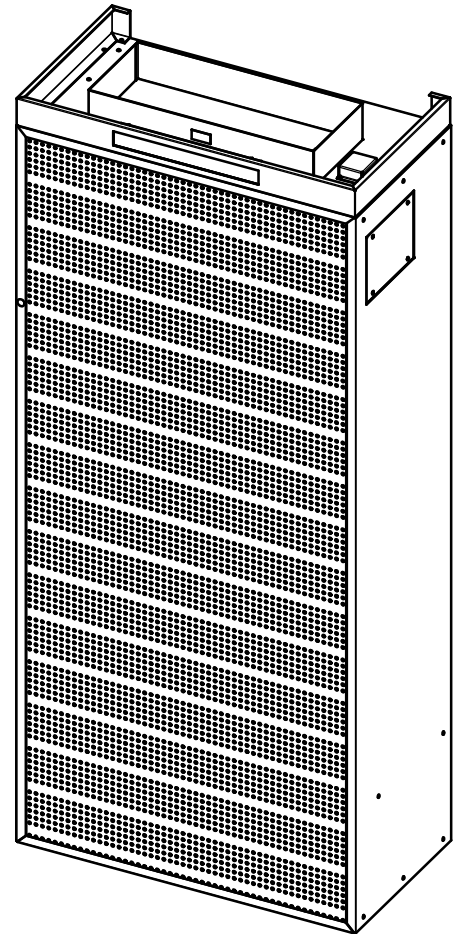
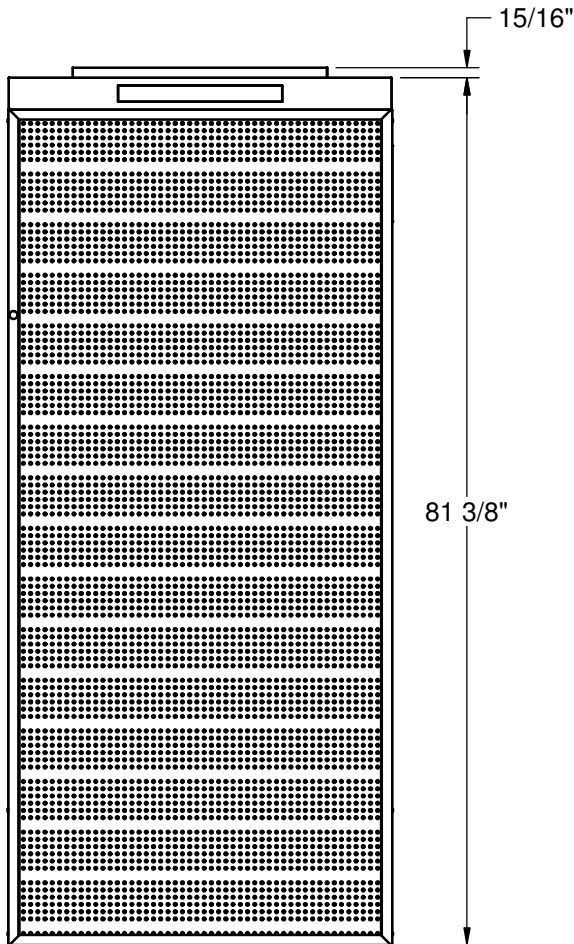
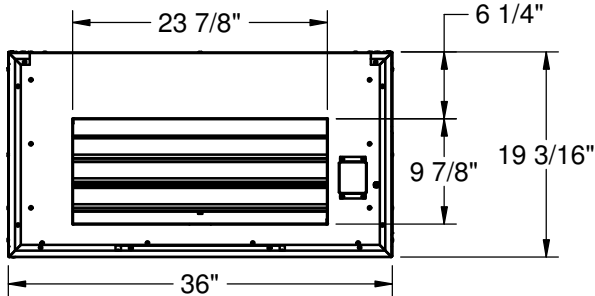

Note: All dimensions are in inches

This submittal is meant to demonstrate general dimensions of this product. The drawings are not meant to detail every aspect of the product. Drawings are not to scale.

Titus reserves the right to make changes without written notice

All rights reserved. No part of this work may be reproduced or transmitted in any form or by any means, electronic or mechanical, including photocopying and recording, or by any information storage retrieval system without permission in writing to Air Distribution Technologies Inc.

DVRI-HCS 24" X 10" RECT. INLET

- Optional telescoping duct cover

Model Unit Size	Diffuser Height with Duct Cover Kit*	
	Max	Min
36 X 81	124"	109 7/8"

*Does not Include Mounting Base Height.

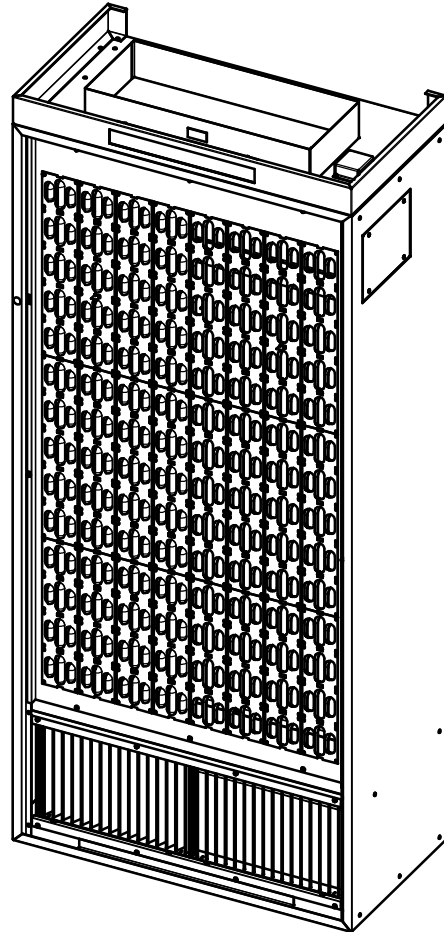
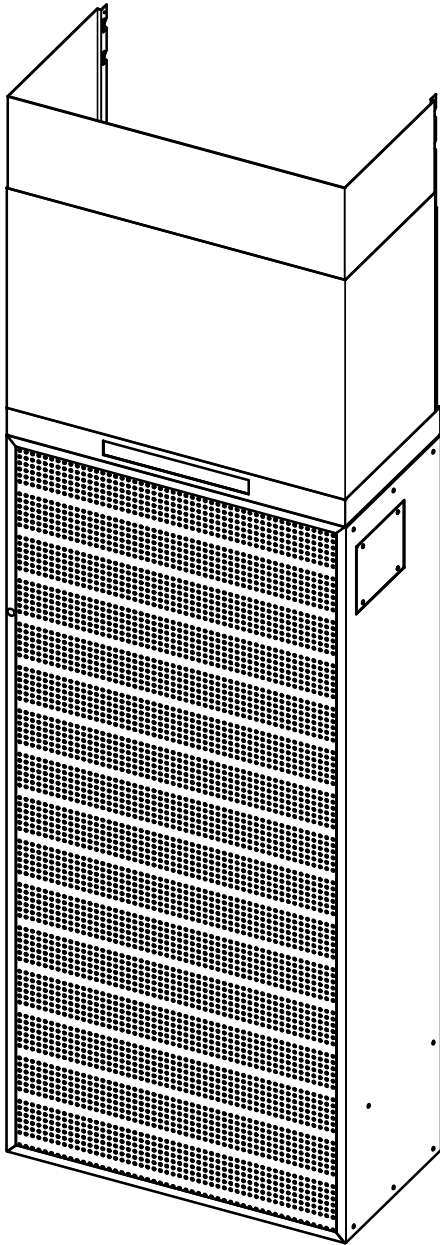

View showing integral variable air pattern controllers

- Optional mounting base height (J): 2-3/4" or 4".

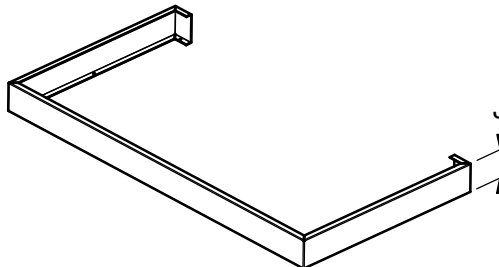

Note: All dimensions are in inches

This submittal is meant to demonstrate general dimensions of this product. The drawings are not meant to detail every aspect of the product. Drawings are not to scale.

Titus reserves the right to make changes without written notice

All rights reserved. No part of this work may be reproduced or transmitted in any form or by any means, electronic or mechanical, including photocopying and recording, or by any information storage retrieval system without permission in writing to Air Distribution Technologies Inc.

DVRI-HCS 24" X 10" RECT. INLET

Model	Inlet Size	Nominal Unit Size
DVRI-HCS	10 x 24	47 x 81

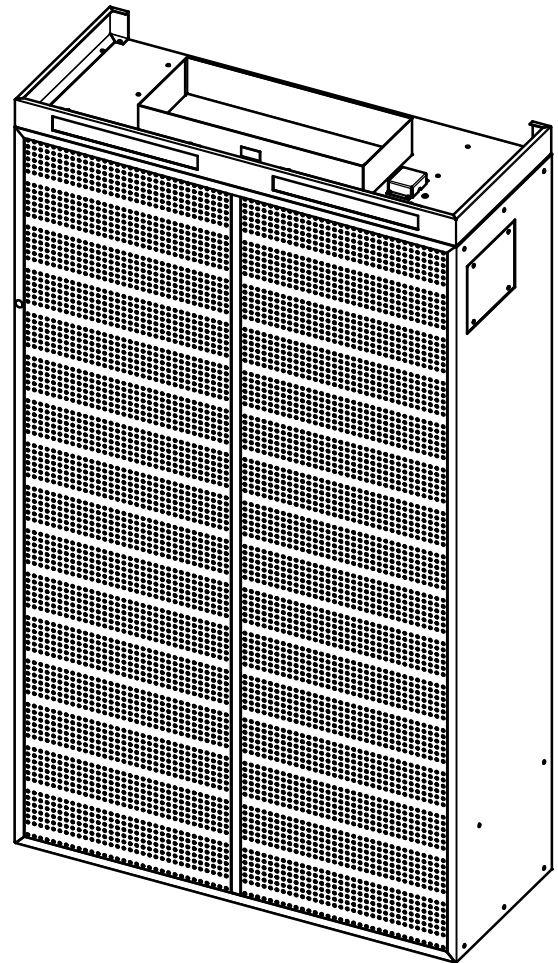
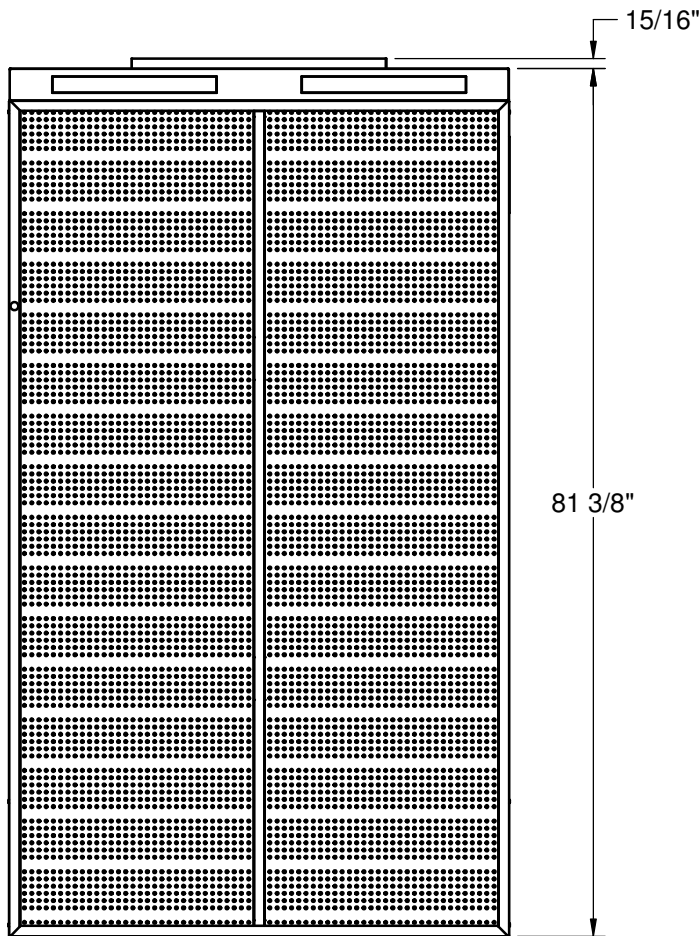
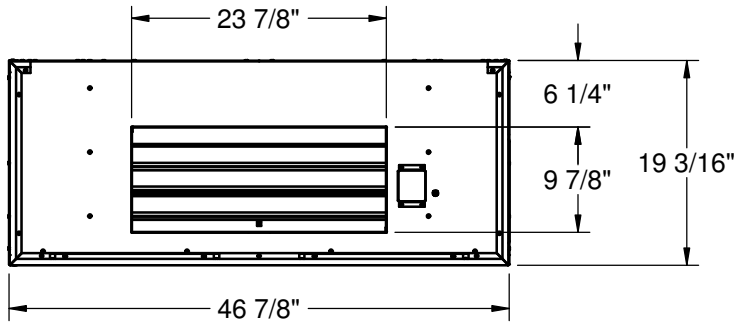

Note: All dimensions are in inches

This submittal is meant to demonstrate general dimensions of this product. The drawings are not meant to detail every aspect of the product. Drawings are not to scale.

Titus reserves the right to make changes without written notice

All rights reserved. No part of this work may be reproduced or transmitted in any form or by any means, electronic or mechanical, including photocopying and recording, or by any information storage retrieval system without permission in writing to Air Distribution Technologies Inc.

DVRI-HCS 24" X 10" RECT. INLET

Model Unit Size	Diffuser Height with Duct Cover Kit*	
	Max	Min
47 x 81	124"	109 7/8"

*Does not Include Mounting Base Height.

- Optional telescoping duct cover

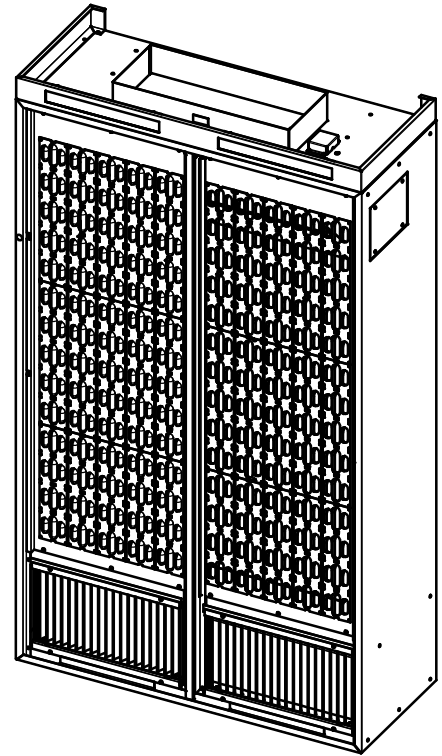
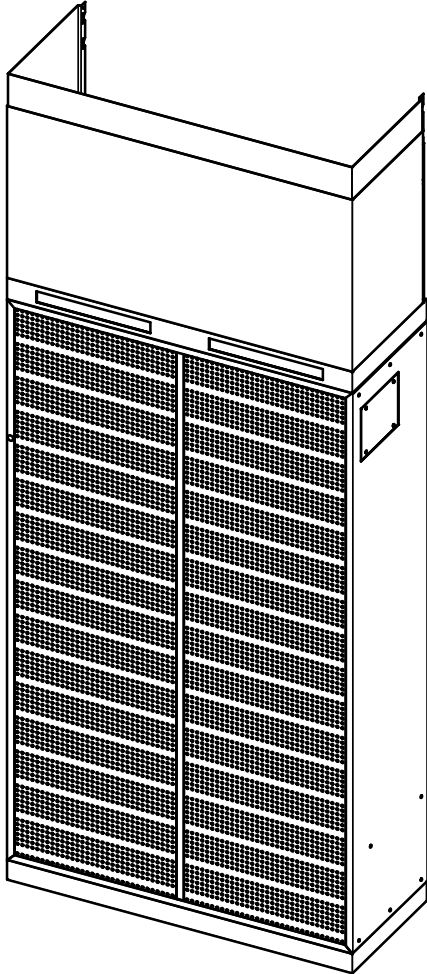

View showing integral variable air pattern controllers

- Optional mounting base height (J): 2-3/4" or 4".

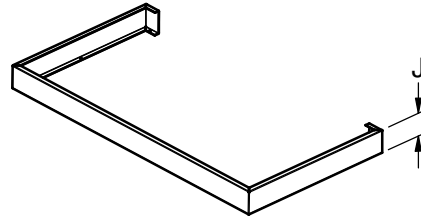

Note: All dimensions are in inches

Displacement diffuser adjustment of adjacent zone (AZ)

The DVRI-HCS design features integral variable pattern controllers located in the unit behind the perforated face. These pattern controllers can be removed and repositioned to change the adjacent zone pattern from the diffuser face (cooling mode only). To adjust the pattern:

- Remove Diffuser face
- Remove Louvers
- Reposition Louvers
- Replace Louvers

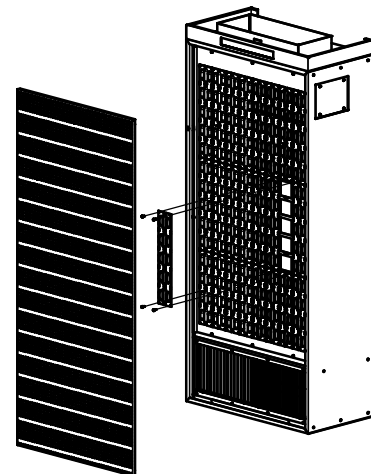

This submittal is meant to demonstrate general dimensions of this product. The drawings are not meant to detail every aspect of the product. Drawings are not to scale.

Titus reserves the right to make changes without written notice

All rights reserved. No part of this work may be reproduced or transmitted in any form or by any means, electronic or mechanical, including photocopying and recording, or by any information storage retrieval system without permission in writing to Air Distribution Technologies Inc.

DVRI-HCS 24" X 10" RECT. INLET

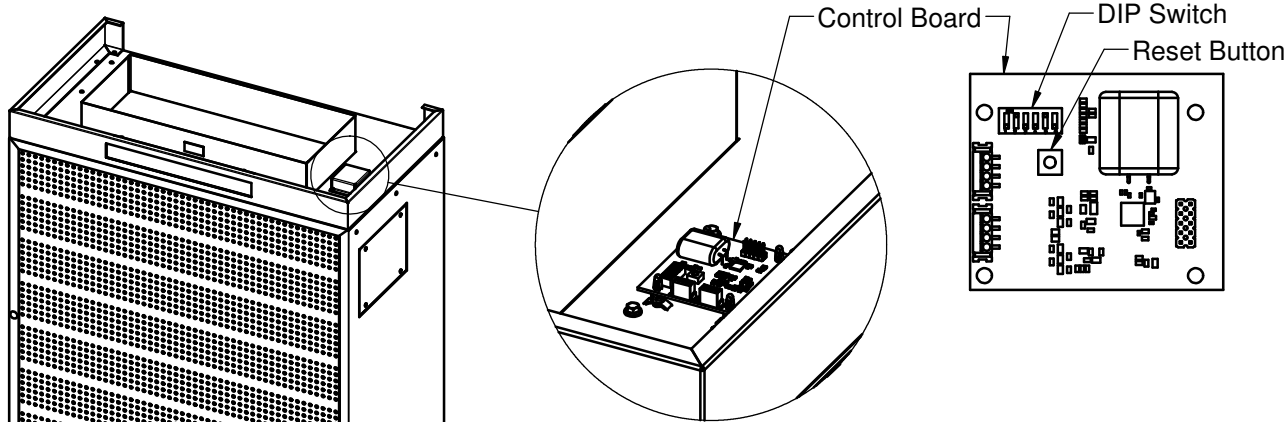

Temperature Band Adjustment

Remove cover protecting the control board. Locate DIP switch on control board. Set both cooling and heating temperatures to desired set point. Only one cooling switch and one heating switch should be in the "ON" position. The remaining switches should be in the "OFF" position. After selecting set points, press the "RESET" button.

Note: Diffusers ship factory with the default temperature set points of 71 °F and 78 °F. (Shown in diagram above)

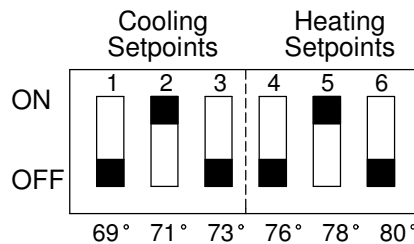

Initial Startup:

The DVRI-HCS Plexicon diffuser utilizes solar energy harvesting to power the internal motor/actuator assemblies and provide the auto-changeover action between cooling and heating blade operations. This is accomplished by exposing the diffuser to room or ambient light to charge the energy accumulator. In most cases, the solar cell will charge the energy storage device in the first few hours of operation.

General Description

- DVRI-HCS Plexicon is a combination displacement/mixed air diffuser that can be positioned against a wall in flush or surface mount applications to provide cooling and perimeter heating in the space
- Dual plenum design directs supply airflow to a displacement diffuser for cooling or deflector vanes for heating
- DVRI-HCS uses displacement principles to cool and mixed airflow principles to heat from a single unit assembly with one supply air inlet connection
- Both internal plenums are connected to motor/actuator assemblies that provides the auto-changeover action for cooling/heating
- No external power is needed for operation. The DVRI-HCS features energy harvesting technology from solar and ambient room light to power the actuators. Internal temperature sensors monitor supply air temperature and automatically directs the supply air to the displacement diffuser for cooling or the deflector vanes for heating
- Solar cells mounted on face collect light energy and stores on internal capacitor
- Smart logic programming on internal P.C. board checks supply air temperature in 10 minute intervals to ensure proper airflow delivery from displacement diffuser for cooling or deflector vanes for heating
- Includes integral variable air pattern controllers for easy adjustment of the air flow spread pattern (cooling section only)
- Includes air volume measurement outlet to facilitate balancing. K-factor is marked on outlet
- Material is galvanized steel and aluminum
- Standard finish is #26 white (powdercoat)
- Available inlet size: 24" x 10" nominal rectangular
- Optional duct cover and mounting base available as accessories

This submittal is meant to demonstrate general dimensions of this product. The drawings are not meant to detail every aspect of the product. Drawings are not to scale.

Titus reserves the right to make changes without written notice

All rights reserved. No part of this work may be reproduced or transmitted in any form or by any means, electronic or mechanical, including photocopying and recording, or by any information storage retrieval system without permission in writing to Air Distribution Technologies Inc.